

## Pressure measurement Pressure transmitters

### Single-range transmitters / SITRANS LH100

#### Overview



The pressure transmitter SITRANS LH100 is a submersible sensor for hydrostatic level measurement.

The pressure transmitter measures the liquid levels in tanks, containers, channels and dams. The SITRANS LH100 pressure transmitters are available for various measuring ranges and with explosion protection as an option.

A cable box and an anchoring clamp are available as accessories for simple installation.

#### Benefits

- Compact design
- Simple installation
- Small error in measurement (0.3 %)
- Degree of protection IP68

#### Application

SITRANS LH100 pressure transmitters are used in the following branches, for example:

- Shipbuilding
- Water/waste water supply
- For use in unpressurized/open vessels and wells

#### Design

The pressure transmitter has a built-in ceramic sensor which is equipped with a Wheatstone resistance bridge.

These pressure transmitters are equipped with an electronic circuit fitted together with the sensor in a stainless steel enclosure. In addition, the connecting cable contains a vent pipe which is equipped with a humidity filter to prevent the build-up of condensation.

The diaphragm is protected against external influences by a protective cap.

The sensor, the electronics and the connecting cable are housed in an enclosure with small dimensions.

The pressure transmitter is temperature-compensated for a wide temperature range.

#### Function

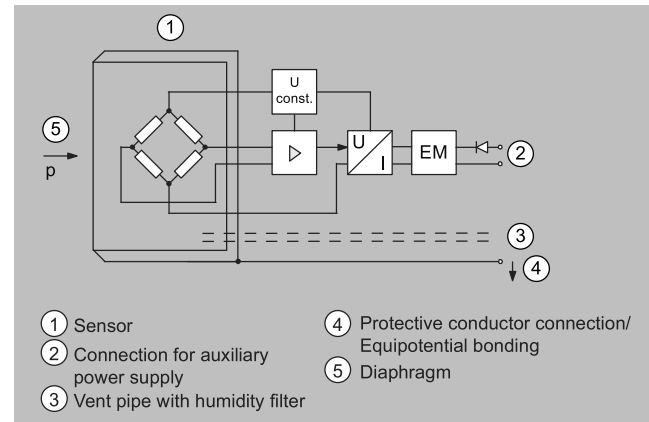

SITRANS LH100 pressure transmitter, mode of operation and connection diagram

On one side of the sensor (1), the diaphragm (5) is exposed to the hydrostatic pressure which is proportional to the submersion depth. This pressure is compared with atmospheric pressure. Pressure compensation is carried out using the vent pipe (3) in the connecting cable. The vent pipe is equipped with a humidity filter which prevents the build-up of condensation in the vent pipe.

The hydrostatic pressure of the liquid column acts on the diaphragm of the sensor and transmits the pressure to the Wheatstone resistance bridge in the sensor.

The output voltage signal of the sensor is applied to the electronic circuit where it is converted into an output current signal of 4 to 20 mA.

The protective conductor connection/equipotential bonding (4) is connected to the enclosure.

## Pressure measurement

### Pressure transmitters

#### Single-range transmitters / SITRANS LH100

##### Integration

It is generally recommended that the connecting cable of the SITRANS LH100 transmitter is connected to the cable box, which can be ordered separately, and secured with the anchoring clamp, also available separately. The cable box has to be installed near the measuring point.

If the medium is anything other than water, it is also necessary to check compatibility with the specified materials of the transmitter.

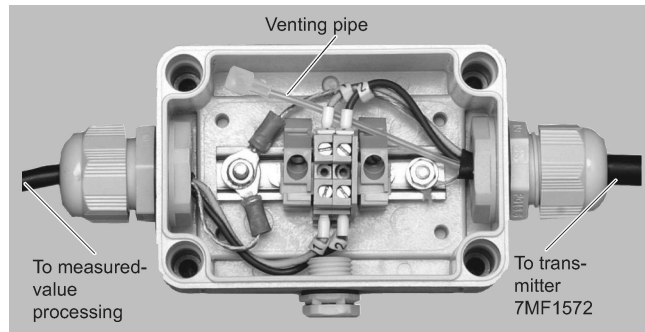

Cable box 7MF1572-8AA, open, schematic diagram



Measuring point setup, generally with cable box 7MF1572-8AA and 7MF1572-8AB cable hanger

Pressure measurement  
Pressure transmitters

Single-range transmitters / SITRANS LH100

Selection and ordering data

SITRANS LH100 pressure transmitter		Article No.	Order code
		7MF1572-	• • A • • • • •
For the measurement of the hydrostatic fill level through submersion 2-wire system, 4 ... 20 mA, enclosure material mat. no. 1.4404 (316 L) Measuring cell Al <sub>2</sub> O <sub>3</sub> ceramic, with permanently mounted PE cable			
<a href="#">Click the article number for online configuration in the PIA Life Cycle Portal.</a>			
Measuring range	Cable length		
0 ... 3 mH <sub>2</sub> O	10 m (≈ 30 ft)	1 C	
0 ... 4 mH <sub>2</sub> O	10 m (≈ 30 ft)	1 D	
0 ... 5 mH <sub>2</sub> O	10 m (≈ 30 ft)	1 E	
0 ... 6 mH <sub>2</sub> O	10 m (≈ 30 ft)	1 F	
0 ... 10 mH <sub>2</sub> O	20 m (≈ 60 ft)	1 H	
0 ... 20 mH <sub>2</sub> O	30 m (≈ 90 ft)	1 K	
0 ... 9 ftH <sub>2</sub> O <sup>1)</sup>	33 ft	2 C	
0 ... 12 ftH <sub>2</sub> O	33 ft	2 D	
0 ... 15 ftH <sub>2</sub> O	33 ft	2 E	
0 ... 18 ftH <sub>2</sub> O	33 ft	2 F	
0 ... 30 ftH <sub>2</sub> O	66 ft	2 H	
0 ... 60 ftH <sub>2</sub> O	98 ft	2 K	
0 ... 0.3 bar <sup>1)</sup>	10 m (≈ 30 ft)	3 C	
0 ... 0.4 bar	10 m (≈ 30 ft)	3 D	
0 ... 0.5 bar	10 m (≈ 30 ft)	3 E	
0 ... 0.6 bar	10 m (≈ 30 ft)	3 F	
0 ... 1 bar	20 m (≈ 60 ft)	3 H	
0 ... 2 bar	30 m (≈ 90 ft)	3 K	
<b>Special designs</b>			
Measuring ranges for special designs between:			
• 0 ... 3 mH <sub>2</sub> O and 0 ... 30 mH <sub>2</sub> O			
• 0 ... 9 ftH <sub>2</sub> O and 0 ... 100 ftH <sub>2</sub> O			
• 0 ... 0.3 bar and 0 ... 3 bar			
<b>Special cable length/special measuring range</b>			
Add "-Z" to article number, specify order code and plain text.		9 A	H . .
<b>Note:</b> Specification of the measuring range Y01 is mandatory!			+ Y 0 1
The following applies to determining the maximum cable length for Ex versions: Transmitters:			
• C <sub>I</sub> = 0 µF, L <sub>I</sub> = 0 µH			
Cables:			
• C <sub>K</sub> = 0.19 nF per meter cable			
• L <sub>K</sub> = 1.5 µH per meter cable			
The max. permissible data of the transmitter infeed device must be taken into account!			
3 m (10 ft)			H 1 A
5 m (16 ft)			H 1 B
7 m (23 ft)			H 1 C
10 m (33 ft)			H 1 D
15 m (49 ft)			H 1 E
20 m (66 ft)			H 1 F
25 m (82 ft)			H 1 G
30 m (98 ft)			H 1 H
40 m (131 ft)			H 1 J
50 m (164 ft)			H 1 K
60 m (198 ft)			H 1 L
70 m (231 ft)			H 1 M
80 m (264 ft)			H 1 N
90 m (297 ft)			H 1 P
100 m (330 ft)			H 1 Q
<b>Gasket material between sensor and enclosure</b>			
FPM (standard)		1	
EPDM (for drinking water applications)		2	
<b>Explosion protection</b>			
None		0	
With explosion protection ATEX II1 G Ex ia IIC T4 Ga and IECEx Ex ia IIC T4 Ga		1	

## Pressure measurement

### Pressure transmitters

#### Single-range transmitters / SITRANS LH100

#### Selection and ordering data (continued)

Options	Order code
<b>Add "-Z" to article number and specify order code.</b>	
Quality inspection certificate (5-point characteristic curve test) according to IEC 62828-2	C11
Specification of measuring range (only with special cable lengths) in: "... to ... mH <sub>2</sub> O" or "... to ... ftH <sub>2</sub> O" or "... to ... bar"	Y01

#### Accessories/spare parts

	Article No.
Cable plug for connecting the transmitter cable	7MF1572-8AA
Anchoring clamp For mounting the pressure transmitter	7MF1572-8AB
Protective caps As a replacement (pack of 10)	7MF1572-8AD
Humidity filter As a replacement (pack of 10)	7MF1572-8AE

## Pressure measurement

## Pressure transmitters

## Single-range transmitters / SITRANS LH100

## Technical specifications

Pressure transmitter SITRANS LH100 (submersible sensor)	
<b>Mode of operation</b>	
Measuring principle	Piezo-resistive
<b>Input</b>	
Measured variable	Hydrostatic level
Measuring range	Max. permissible operating pressure
• 0 ... 3 mH <sub>2</sub> O (0 ... 9 ftH <sub>2</sub> O)	• 1.5 bar (21.8 psi) (corresponds to 15 mH <sub>2</sub> O (45 ftH <sub>2</sub> O))
• 0 ... 4 mH <sub>2</sub> O (0 ... 12 ftH <sub>2</sub> O)	• 1.5 bar (21.8 psi) (corresponds to 15 mH <sub>2</sub> O (45 ftH <sub>2</sub> O))
• 0 ... 5 mH <sub>2</sub> O (0 ... 15 ftH <sub>2</sub> O)	• 1.5 bar (21.8 psi) (corresponds to 15 mH <sub>2</sub> O (45 ftH <sub>2</sub> O))
• 0 ... 6 mH <sub>2</sub> O (0 ... 18 ftH <sub>2</sub> O)	• 1.5 bar (21.8 psi) (corresponds to 15 mH <sub>2</sub> O (45 ftH <sub>2</sub> O))
• 0 ... 10 mH <sub>2</sub> O (0 ... 30 ftH <sub>2</sub> O)	• 3.0 bar (43.5 psi) (corresponds to 30 mH <sub>2</sub> O (90 ftH <sub>2</sub> O))
• 0 ... 20 mH <sub>2</sub> O (0 ... 60 ftH <sub>2</sub> O)	• 5.0 bar (72.5 psi) (corresponds to 50 mH <sub>2</sub> O (150 ftH <sub>2</sub> O))
• 0 ... 0.3 bar	• 1.5 bar
• 0 ... 0.4 bar	• 1.5 bar
• 0 ... 0.5 bar	• 1.5 bar
• 0 ... 0.6 bar	• 1.5 bar
• 0 ... 1 bar	• 3.0 bar
• 0 ... 2 bar	• 5.0 bar
<b>Output</b>	
Output signal	4 ... 20 mA
<b>Measuring accuracy</b>	According to IEC 62828-1
Measurement deviation at limit setting including hysteresis and reproducibility	
Measuring range	
• 0 ... 3 mH <sub>2</sub> O (0 ... 9 ftH <sub>2</sub> O or 0 ... 0.3 bar)	• 0.5% measuring range end value (typical) • 1.0% of measuring range end value (maximum)
• For all other measuring ranges	• 0.3% of measuring range end value (typical) • 0.6% of measuring range end value (maximum)
<b>Effect of ambient temperature</b>	
Measuring range	Zero and span
• 3 mH <sub>2</sub> O (9 ftH <sub>2</sub> O or 0.3 bar)	0.45%/10 K of measuring range end value
• 4 ... 6 mH <sub>2</sub> O (12 ... 18 ftH <sub>2</sub> O or 0.4...0.6 bar)	0.45%/10 K of measuring range end value
• > 6 mH <sub>2</sub> O (> 18 ftH <sub>2</sub> O or > 0.6 bar)	0.3%/10 K of measuring range end value
<b>Long-term stability</b>	
Measuring range	Zero and span
• 3 mH <sub>2</sub> O (9 ftH <sub>2</sub> O or 0.3 bar)	0.4% of measuring range end value/year
• 4 ... 6 mH <sub>2</sub> O (12 ... 18 ftH <sub>2</sub> O or 0.4...0.6 bar)	0.25% of measuring range end value/year
• > 6 mH <sub>2</sub> O (> 18 ftH <sub>2</sub> O or > 0.6 bar)	0.2% of measuring range end value/year
<b>Operating conditions</b>	
Ambient conditions	
• Process temperature	-10 ... +80 °C (14 ... 176 °F)
• Storage temperature	-40 ... +80 °C (-40 ... +176 °F)
Degree of protection according to IEC 60529	IP68
<b>Structural design</b>	
Weight	
• Pressure transmitter	≈ 0.2 kg (≈ 0.44 lb)

## Technical specifications (continued)

Pressure transmitter SITRANS LH100 (submersible sensor)	
• Cable; maximum cable length 100 m (330 ft)	0.025 kg/m (≈ 0.015 lb/ft)
Electrical connection	Cable with 3 conductors, vent pipe and integrated humidity filter
<b>Material</b>	
• Seal diaphragm	Al <sub>2</sub> O <sub>3</sub> ceramic, 96%
• Enclosure	Stainless steel, mat. no. 1.4404/316L
• Gasket	• FPM (standard) • EPDM (optional)
• Connecting cable	• PE-HD (standard) • PE-LD (in the case of versions with EPDM seal, suitable for drinking water applications)
<b>Auxiliary power</b>	
Terminal voltage on pressure transmitter U <sub>B</sub>	• 10 ... 33 V DC • 10 ... 30 V DC for transmitter with intrinsic safety explosion protection
<b>Certificates and approvals</b>	
Drinking water approval (ACS)	15 ACC NY 360
EAC	№ TC RU C-DE.ГБ05.В.00732 OC НАННО «ЦСБЭ»
Underwriters Laboratories (UL)	2014-11-17 - E344532
The device is not subject to the pressure equipment directive (PED 2014/68/EU)	
Explosion protection	
• Intrinsic safety "i"	IECEX SEV 14.0003 SEV 14 ATEX 0109
- Marking	II 1 G Ex ia IIC T4 Ga
• EAC Ex	TC RU C-DE.AA87.B.00324

## Cable box

Cable box	
<b>Area of application</b>	For connecting the transmitter cable
<b>Structural design</b>	
Weight	0.2 kg (0.44 lb)
Electrical connection	2 x 3-way (28 to 18 AWG)
Cable entry	2 x Pg 9
Enclosure material	Polycarbonate
Vent valve for atmospheric pressure	
<b>Operating conditions</b>	
Degree of protection according to IEC 60529	IP65

## Anchoring clamp

Anchoring clamp	
<b>Area of application</b>	For mounting the transmitter
<b>Structural design</b>	
Weight	0.16 kg (0.35 lb)
Material	Zinc-plated steel, polyamide

## Pressure measurement

### Pressure transmitters

#### Single-range transmitters / SITRANS LH100

##### Dimensional drawings

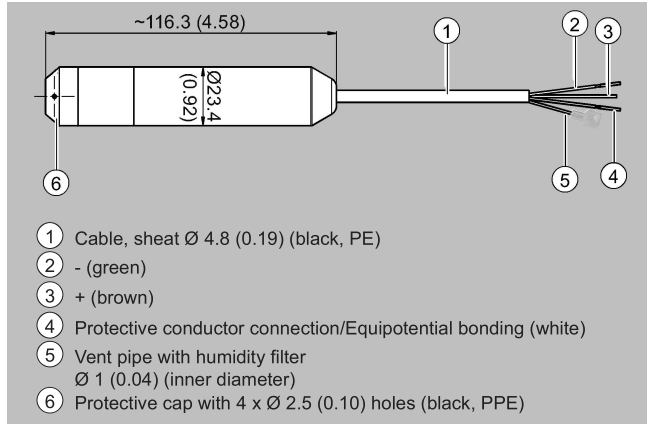

SITRANS LH100 pressure transmitter, dimensions in mm (inch)

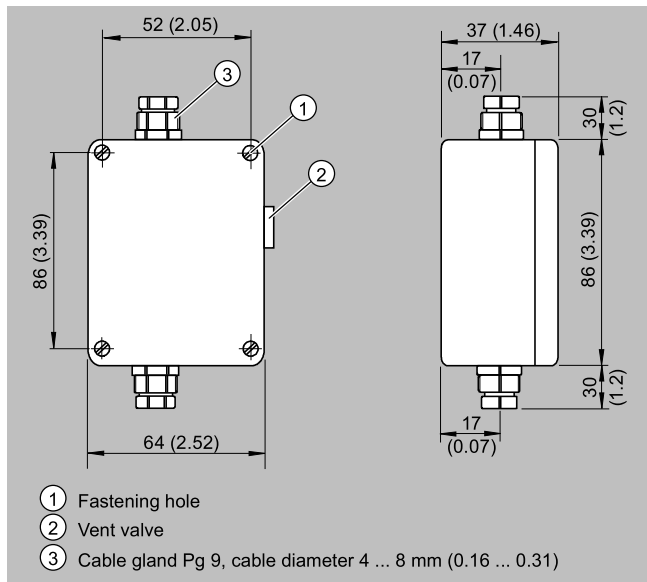

Junction box, dimensions in mm (inch)

##### Dimensional drawings (continued)

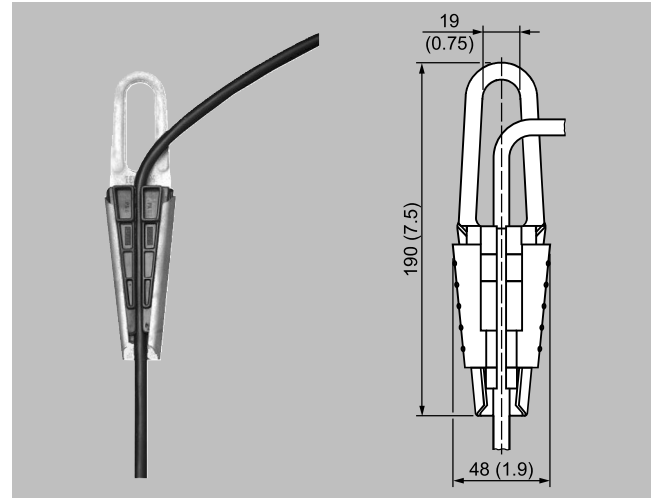

Anchoring clamp, dimensions in mm (inch)

**More information**

*Establishing the measuring range with water as process medium*

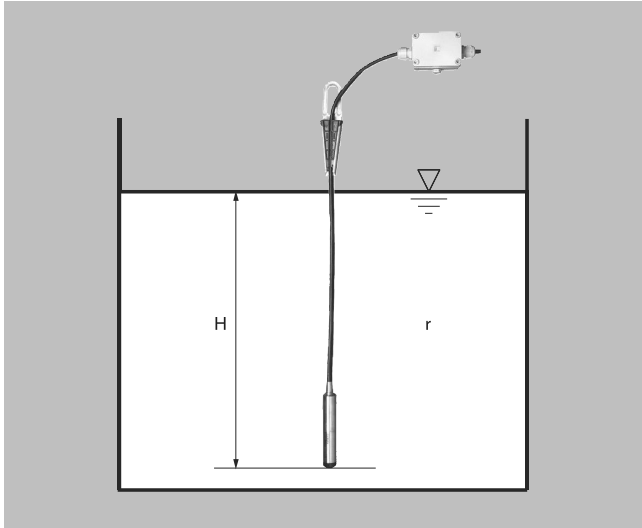
Calculation of the measuring range

$$p = \rho \times g \times H$$

with:

$\rho$  = density of medium

$g$  = local gravitational acceleration

$H$  = maximum level

Example:

Medium: Water,  $\rho = 1\,000\text{ kg/m}^3$

Gravitational acceleration:  $9.81\text{ m/s}^2$

Lower range value: 0 m

Maximum level: 6.0 m

Cable length: 10 m

Calculation:

$$p = 1\,000\text{ kg/m}^3 \times 9.81\text{ m/s}^2 \times 6.0\text{ m}$$

$$p = 58\,860\text{ N/m}^2$$

$$p = 589\text{ mbar}$$

Transmitter to be ordered:

**7MF1572-1FA10**

Plus, if required, cable box 7MF1572-8AA and anchoring clamp 7MF1572-8AB